

# ARONSON Series

## Locust I & II



Koike Aronson / Ransome gear elevated Locust series manipulators are designed for safety and a trouble free long life. All critical mechanisms are enclosed and load carrying gear cases are welded in place and lifetime lubricated. Both lift and reach axis are guided with concave wheels and roundways for precision movement.

For small to medium industrial applications which require a small to medium arc travel and load capacity without the location of the operator on the boom, the Locust series manipulators are the solution.

Self-standing bases, travel cars and welding equipment packages are just some of the options available.

**Lift and reach ranging from 6 ft to 12 ft**



**KOIKE ARONSON, INC. / RANSOME**

## Features

- Load capacities up to 600 pounds
- NEMA 12 Electricals
- Floor-base or car-track options available
- Large variety of accessories and options for versatility
- Low voltage hand control pendants
- Variable speed drives
- Round rail guidance on lift and reach axis
- Rack and pinion lift
- Optional mast rotation



**Standard hand pendant provided with all models**

# Specifications

## Locust

Model	Locust-I	Locust-II
Reach Travel Speed (IPM)	100 - 3.3 ipm	100 - 2.0 ipm
Reach motor HP	½ hp	½ hp
<b>DIM A:</b> Standard reach travel	6 ft	6 ft
Maximum reach travel	8 ft	12 ft
<b>DIM B:</b> Standard Min. reach distance from CL of Mast	13 in	15-½ in
<b>DIM C:</b> Standard Max. reach distance from CL of Mast	73 in	87-½ in
Boom mounting plate dimensions	½ x 4 x 10 in	¾ x 4-½ x 9 in
<b>DIM D:</b> Standard height overall (HOA) from floor to top of machine	107 in	114-¼ in
Lift speed	32 ipm	34 ipm
Lift motor HP	¾ hp	¾ hp
<b>DIM E:</b> Min. lift height from floor to CL of boom	24 in	28-¾ in
Max. lift travel	8 ft	12 ft
<b>DIM F:</b> Std. Lift travel distance from CL of boom	6 ft	6 ft
Base dimension	1 x 15-¼ in (diameter)	1-½ x 24 in (diameter)
Standard machine voltage	120/1/60	460/3/60

All dimensions are for reference only and subject to change without notice.

Model	Locust- I	Locust- II
6 ft x 6 ft	400 lb	600 lb
7 ft x 7 ft	350 lb	500 lb
8 ft x 8 ft	300 lb	500 lb
9 ft x 9 ft		400 lb
10 ft x 10 ft		400 lb
12 ft x 12 ft		300 lb

Maximum load in pounds on either or both ends of boom

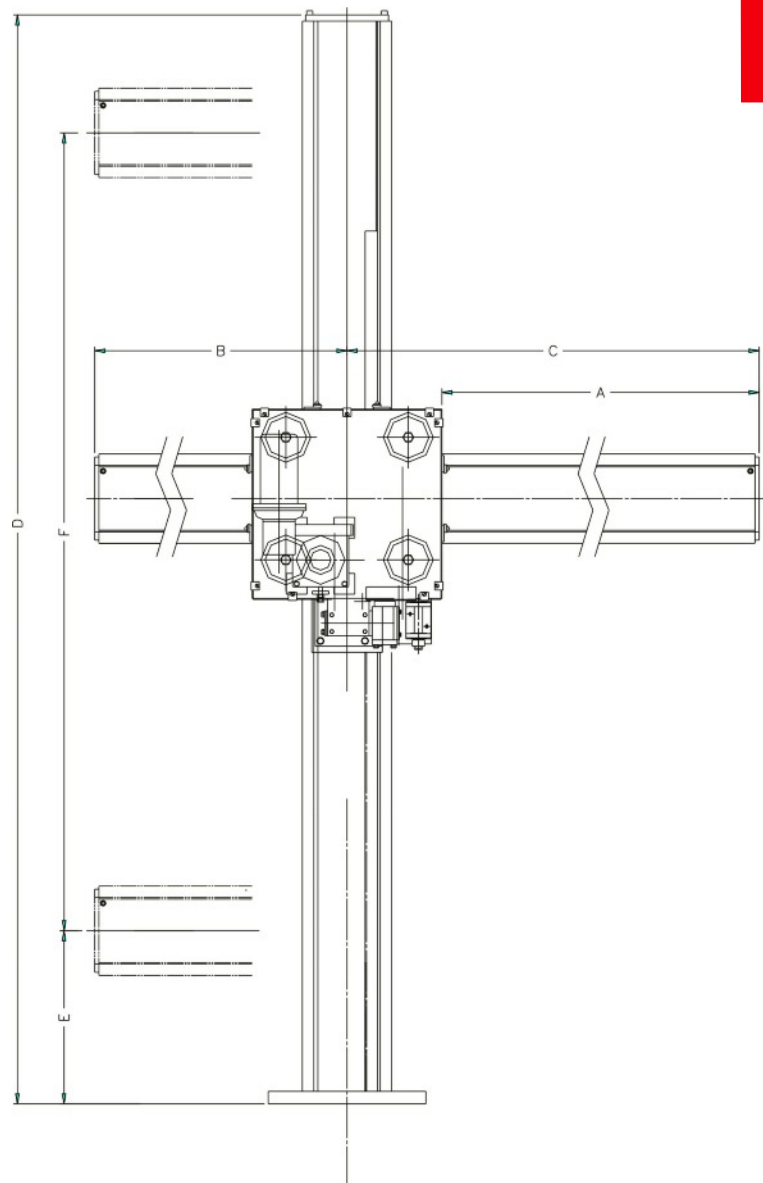

See page 6 for car and base options  
& page 22 for all machine options.