

## Trac-Tred Turning Rolls

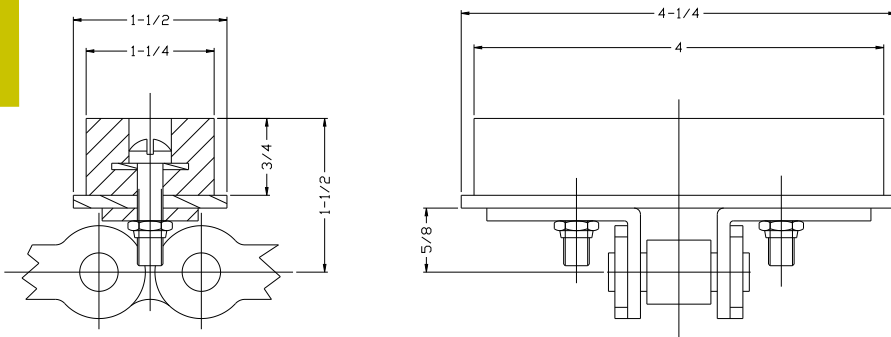
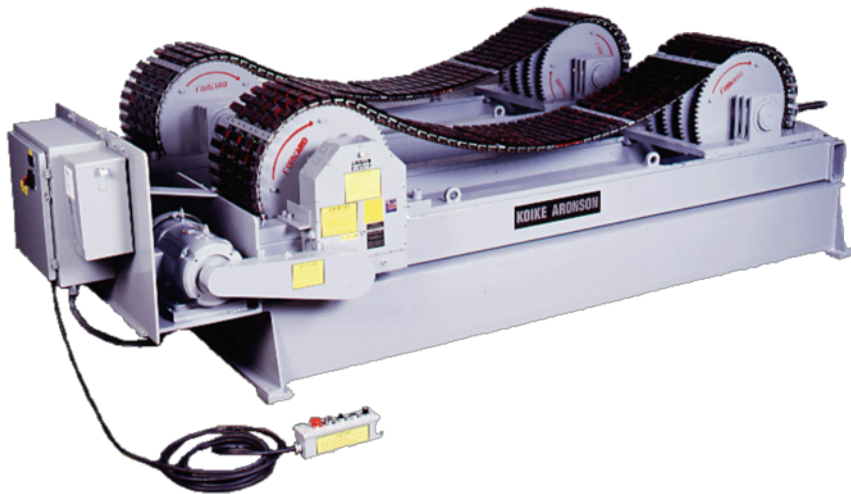

Koike Aronson, Inc./ Ransome's Trac-Tred Turning rolls provide the solution for safely turning thin walled or precious surfaced cylindrical pieces without marring, wrinkling or indenting the vessel. The patented Trac-Tred system allows for steady, precise rotation of vessels from 4 ft to 20 ft, with capacities up to 24,000 lb.

Specifications	T1 (Single Strand)	T2 (Double Strand)	T3 (Triple Strand)	T4 (4 Strand)
Load Capacity	6,000 lb	12,000 lb	18,000 lb	24,000 lb
Speed, IPM	80 -1.6 IPM	80 -1.6 IPM	74 -1.5 IPM	74 -1.5 IPM
Tractive Pull	1,000 lb	1,000 lb	2,000 lb	3,000 lb
Std. Dia. Range	4' - 10' Dia.	6' - 12' Dia.	16' - 20' Dia.	16' - 20' Dia.

### Precision Rotation of Thin Walled Vessels

## Features

- Various materials for pads
- NEMA 12 Electricals
- Thin walled vessels
- Low voltage hand control pendants
- 50:1 Variable speed drives



**Standard hand pendant provided with all models**



**Optional foot switch controls available**