

**Portable Automatic Gas Cutter**



BAA04E12

# **Handy Auto PLUS**

## **OPERATION MANUAL**



**For every person who will be engaged in operation and maintenance supervision, It is recommended to read through this manual before any operations, so as to permit optimum operation of this machine.**

**KOIKE SANZO KOGYO CO.,LTD.**



## **INTRODUCTION**

**Thank you very much for purchasing this product. Read this instruction manual thoroughly to ensure correct, safe and effective use of the machine. Read the manual first to understand how to operate and maintain the machine.**

**Make sure you read, understand and take all the necessary safety precautions.**









## **SAFETY PRECAUTIONS**

**This product is designed to be safe, but it can cause serious accidents if not operated correctly. Those who operate and repair this machine must read this manual thoroughly before operating, inspecting and maintaining the machine. Keep the manual near the machine so that anyone who operates the machine can refer to it if necessary.**

- Do not use the machine carelessly without following the instructions in the manual.
- Use the machine only after you completely understood the contents of the manual.
- If an explanation in the manual is difficult to understand, contact our company or sales service office.
- Keep the manual near by at all times and read it as many times as necessary for a complete understanding.
- If the manual becomes lost or damaged, place an order with our company or sales service office for a new one.
- When transferring the machine to a new owner, be sure to hand over this instruction manual as well.

## **QUALIFICATIONS FOR MACHINE OPERATOR**

**Operators and repair staff of this machine must completely understand the contents of the instruction manual and they must be qualified and educated to handle this equipment.**

Symbol	Title	Meaning
	General	General caution, warning, and danger.
	Be careful not to get your fingers caught.	Possible injury to fingers if caught in the insertion part.
	Caution: Electric shock!	Possible electric shock under special conditions.
	Ground this equipment.	Operators must ground the equipment using the safety grounding terminal.
	Pull out the power plug from the outlet.	Operators must unplug the power plug from the outlet when a failure occurs or when there is a danger of lightning.
	Caution against bursting	Possible bursting under certain conditions.
	General	General warning.
	Caution: Hot!	Possible injury due to high temperature under certain conditions.
	Caution: Ignition!	Possible ignition under certain conditions.

# CONTENTS

1. Safety Information .....	3
■ WARNING .....	3
■ CAUTION .....	3
■ NOTICE SIGNS .....	3
1.1 General machine safety precautions .....	3
1.1.1 Machine safety .....	3
1.1.2 Safety clothing .....	3
1.1.3 Operations and handling safety precautions .....	3
1.1.4 Electrical system precautions .....	5
1.1.5 Maintenance and inspection precautions .....	5
1.2 Gas cutting safety precautions .....	5
1.2.1 Prevention of explosion .....	5
1.2.2 Pressure regulator safety precautions .....	5
1.2.3 High pressure gas cylinder safety precautions .....	5
1.2.4 Safety precautions for hoses .....	6
1.2.5 Safety precautions for fire .....	6
1.2.6 Safety precautions for skin burns .....	6
2. Locations of safety labels .....	7
3. Outline of machine .....	8
3.1 Features of machine .....	8
3.2 Name and function of each section .....	8
3.3 Specifications .....	9
4. Preparation for operation .....	9
4.1 Contents of package .....	9
4.2 Machine assembly .....	10
4.3 Preparation for operation .....	10
4.3.1 Connecting the power cable .....	10
4.3.2 The method of setting the Pilot Burner .....	10
4.3.3 Connecting the tip .....	12
4.3.4 Installing the wheel .....	12
4.3.5 Fitting the wheel .....	12
4.3.6 Cutting process .....	13
4.3.7 Speed setting .....	13
4.3.8 Changing over direction of motor rotation .....	13
4.3.9 How to use the guide roller .....	13
4.4 Other attachment .....	14
4.4.1 Auxiliary wheel .....	14
4.4.2 Beveling wheel .....	14
4.4.3 Small circle cutting attachment .....	14
4.4.4 Straight line cutting rail (optional) .....	15
4.4.5 Manual guide lever .....	16
4.4.6 Large circle cutting attachment (optional) .....	16
5. Cutting operation .....	18
5.1 Safety measures prior to operation .....	18
5.1.1 Precaution for handling AC adapter .....	18
5.1.2 Selection of tip .....	18

---

5.1.3 Travelling direction changeover switch .....	18
5.2 Ignition, Extinguishes flame and Flame adjustment .....	18
5.2.1 Gas supply .....	18
5.2.2 Procedure of ignition .....	18
5.2.3 Flame adjustment .....	19
5.2.4 Preheating .....	20
5.2.5 Procedure of extinguishing flame .....	20
5.2.6 Only pilot flame ON/OFF .....	20
5.2.7 Photograph of ignition lever unit .....	20
5.2.8 Lock system of the lever for ignition .....	21
5.2.9 Lock system of valve .....	21
5.3 Cutting and piercing method .....	22
5.4 Procedures for starting cutting operation and extinguishing the flame .....	23
5.4.1 Thin plate cutting .....	23
5.4.2 Bevel cutting .....	23
5.5 Safety measures against backfire and flashback .....	24
5.5.1 Prevention of backfire .....	24
5.5.2 Prevention of flashback .....	24
6. Maintenance and inspection .....	24
6.1 Wheel maintenance .....	24
6.2 Tip maintenance .....	24
6.3 Lubrication .....	25
6.4 Inspection of the gas leakage .....	25
7. Trouble shooting .....	25
8. Wiring diagram .....	26
9. Electrical diagram .....	26
10. Assembly drawing of Handy Auto PLUS .....	27
11. Parts list .....	28
11.1 Main units .....	28
11.2 Option unit .....	30
11.3 Pilot unit assy .....	32
11.4 Safety lock assy .....	32
12. Cutting Data .....	33

## 1 Safety information

Operation, inspection, and maintenance that disregard the basic safety rules cause many accidents. Carefully read, understand, and master the safety measures and precautions described in this instruction manual and on the machine before operating, inspecting, and maintaining the machine.

The safety messages are classified as indicated on the machine safety labels:

### ■WARNING



This word is used in a warning message and a warning label is positioned at places that could cause injury or serious accident.

### ■CAUTION



This word is used in a caution message and a caution label is positioned at places that could cause slight injury or machine damage. This is also used as a caution for frequent dangerous actions.

### ■NOTICE SIGNS



This is a sign to show machine operators and maintenance engineers items that relate directly to damage of machines and surrounding facilities and equipment.

## 1.1 General machine safety precautions

Read and fully understand the following important safety information:

### 1.1.1 Machine safety

- 1.The machine casing is mainly made of aluminum alloy to reduce weight. For this reason, be careful not to drop a heavy item on the machine, or not drop the machine when carrying it, since the alloy is not designed to withstand such impact.
- 2.When mounting hoses to the torch and distributor, tighten the nut with the attached wrench. After mounting, be sure to check there is no gas leak with a detection liquid. If a gas leak is found, retighten the nut firmly.
- 3.When fixing a tip to the torch, tighten the nut with the two wrenches attached. In addition, avoid damaging the taper part of the tip since this may cause backfire.
- 4.Never disassemble the machine other than during maintenance and inspection. Otherwise, malfunction will result.
- 5.Never remodel the machine. Remodeling is very dangerous.
- 6.When changing the travel direction, make sure that the direction switch is in the neutral (stop) position, and operate the direction switch after the machine has stopped.
- 7.Always turn the power off when not used.
- 8.Never use the machine outdoors when the weather is wet. This will cause failure of the machine and could cause a fatal accident by electric shock.

### 1.1.2 Safety clothing

- 1.Be sure to wear protector's gauntlets, goggles, helmet, and safety shoes during operation.
- 2.Avoid operating the machine with wet clothes or hands in order to prevent electric shock.

### 1.1.3 Operation and handling safety precautions

1. Read this instruction manual before operating the machine.

2. Mount and center the machine correctly and confirm correct motion before operation.
  3. Check that the drive knob is at "0" before supplying power.
  4. Prior to operating the machine, check the safety of the surroundings to avoid accidents.
  5. Never move the machine while the preheat flame is on.
  6. When a large-circle cutting attachment is used and the magnet is attached to the steel plate, be careful not to get your fingers caught between the magnet and the steel plate.  
The magnet is powerful.
  7. Be careful that the center of the small-circle cutting attachment is pointed.
  8. The stopper spring is very strong, so be very careful not to get your fingers caught when attaching the standard wheel and small circle cutting attachment.
  9. When cutting along a straight line, be sure to tighten the wheel lock knob; otherwise the wheel position will change.
  10. When a large-circle cutting is about to be completed, be careful that the machine and cut material do not drop.
  11. Be sure to tighten the adjustment screw for locking accessories (standard wheel and small-circle cutting attachment).
  12. Traveling direction changeover switch.
    - The traveling direction changeover switch on the machine is used to change forward/backward movement to linear cutting and clockwise/counterclockwise turning for circular cutting. Check the traveling direction or turning direction before cutting.
    - To change the traveling direction, set the drive knob to the stop position. Then after the machine has stopped completely, change the traveling direction.
- Note: Before turning on the power, be sure to check that the drive knob is in the stop position. If the drive knob is on, it is dangerous to start the machine.**
13. Never touch the rotary section (universal joint) when the machine is travelling.  
It is very dangerous.
  14. Keep clean the roller traveling surface of rail and roller itself in order to avoid knocking during traveling.
  15. The area near the gas hose joint will be gripped, so connect the gas hose correctly.
  16. Be sure the preheat oxygen and gas valves when checking the motion of machine before operation and cutting position.
  17. After cutting, the wheels, bracket, head cover, locking knob, etc. will be very hot.  
Be sure to wear gloves when touching them.
  18. After cutting, do not strike the material with the tip, wheel or head.
  19. When thrown or dropped, the machine life will be shortened, and the possible damage to the valve will cause gas leakage.
  20. Never pull the power cable.
  21. Do not place the machine directly on sand or mud.
  22. Do not lay the machine on its side with the preheat flame on.
  23. Be sure to use a hose band to prevent danger.
  24. Do not hold the turning of the universal joint or insert an object between the joint and conduit tube; otherwise motor trouble will occur.
  25. When the fuse is blown out frequently, never use a fuse for higher amperage without confirming the cause.
  26. Hold the handle when carrying the machine.
  27. Do not put in the hand, clothes etc. absolutely, because there are small gap between the radius adjustment bar and machine body when cutting small circle. Please pay attention sufficient so as not to be put.
  28. As for this machine the drive may not stop even the volume is set at O. indication.  
Please turn off the drive switch certainly after use.



### 1.1.4 Electrical system precautions



1. Be sure to check the input power voltage of the machine before operation. The input power voltage should be in the range of  $\pm 10\%$  of the rated voltage. The machine should not be operated out of this range.
2. The metal plugs are screw-threaded, therefore, fully tighten them so that they will not come loose during operation.
3. **Stop operation and turn off the power in the following cases, and ask a qualified electrician to repair the machine.**



- 1) Broken or abraded cables
  - 2) When the machine has been in contact with water, or in case of liquid damage to the machine.
  - 3) Abnormal machine operation despite operating the machine according to the instruction manual
  - 4) Machine breakdown
  - 5) Poor machine performance that requires repair
4. Periodically inspect the electrical system.

### 1.1.5 Maintenance and inspection precautions



1. Ask a qualified electrician to perform repair and inspection service.
2. Disconnect the power plug before inspecting and repairing the machine.
3. Maintain the machine periodically.

## 1.2 Gas cutting safety precautions

Strictly observe the safety rules and precautions to ensure the safety of gas cutting operations. Operators and supervisors **MUST** keep safety in mind.

### 1.2.1 Prevention of explosion



1. Never cut pressurized cylinders or hermetically sealed containers.
2. Ensure sufficient ventilation for gas cutting to prevent the air from becoming stale.

### 1.2.2 Pressure regulator safety precautions



1. Before starting operation, check that all pressure regulators are operating correctly.
2. Ask a skilled repair engineer to perform maintenance and inspection service.
3. Do not use pressure regulators from which gas is leaking, nor malfunctioning pressure regulators.
4. Do not use pressure regulators smeared with oil or grease.

### 1.2.3 High-pressure gas cylinder safety precautions



1. Never use broken cylinders or cylinders from which gas are leaking.
2. Install cylinders upright and take measures to prevent them from falling.
3. Use cylinders only for specified purposes.
4. Do not smear container valves with oil or grease.
5. Install cylinders in a place free from heat, sparks, slag, and open flame.
6. Contact the distributor if the container valves will not open.

Never use a hammer, wrench, or other tools to forcibly open container valves.

### 1.2.4 Safety precautions for hoses



1. Use the oxygen hose for oxygen gas only.
2. Replace cracked hoses or other hoses damaged by sparks, heat, unshielded fire, etc.
3. Install hoses without twisting.
4. To prevent breakage of hoses, take great care during operation and transportation.
5. Do not hold the hoses when moving the machine.
6. Periodically check the hoses for damage, leakage, fatigue, loose joints, etc. to ensure safety.
7. Cut hoses to the minimum possible length. Short hoses reduce hose damage and pressure drop, as well as reduce the flow resistance.

### 1.2.5 Safety precautions for fire



Take safety precautions to prevent fire prior to gas cutting.

Ignoring hot metal, sparks, and slag could cause a fire.

1. Keep a fire extinguisher, fire extinguish sand, bucket full of water, etc. ready on the site where gas cutting is performed.
2. Keep flammables away from the cutting area to avoid exposure to sparks.
3. Always cool down steel plates that have become hot after cutting, as well as hot cut parts or scrap, before bringing them close to flammables.
4. Never cut containers to which flammable materials are stuck.

### 1.2.6 Safety precautions for skin burns



Observe the safety precautions to prevent skin burns. Ignoring heat, spatter, and sparks during operation could cause a fire or burned skin.

1. Do not perform cutting near flammables. (Move flammables well away from the sparks.)
2. Do not cut containers filled with flammables.
3. Do not keep lighters, matches, and other flammables nearby.
4. Flames from the torch will burn the skin. Keep your body away from the torch and tip, and check the safety before operating the switches and valves.
5. Wear the correct protectors to protect your eyes and body.
6. Correctly tighten the tip to prevent backfire.
  - When fixing a tip to the torch, tighten the nut with the two wrenches attached.
  - If the tip is tightened excessively, it will be heated during cutting and tightened still more, making it difficult to remove the tip.
  - Avoid damaging the taper of the tip since this may cause backfire.
7. Check with soapsuds for any leakage of gas from the connection part of the distributor, hose and torch. Never use oil or grease on the connection of the oxygen pipe to avoid backfire which may lead to explosion.
8. Be sure to check the following when igniting:
  - Always wear the required protectors (gauntlets, helmet, goggles, etc.)
  - Check for any obstacles, dangerous materials and flammables near or in the direction of cutting. Determine the gas pressure.
  - The gas pressure must be within the appropriate range. (For the gas pressure, refer to the Cutting Data.)
9. The torch, tip and heat shield are heated to a very high temperature. Always wear gauntlets when handling them. Also the surface after cutting is very hot so do not touch it even while wearing gauntlets.
10. Extinguishes flame before carrying the machine to avoid danger.

## 2 Locations of safety labels

Safety labels and other labels for correct operation are affixed to the machine. Carefully read the labels and follow the instructions on them when operating the machine. Never remove the labels. Keep them clean and legible at all times.

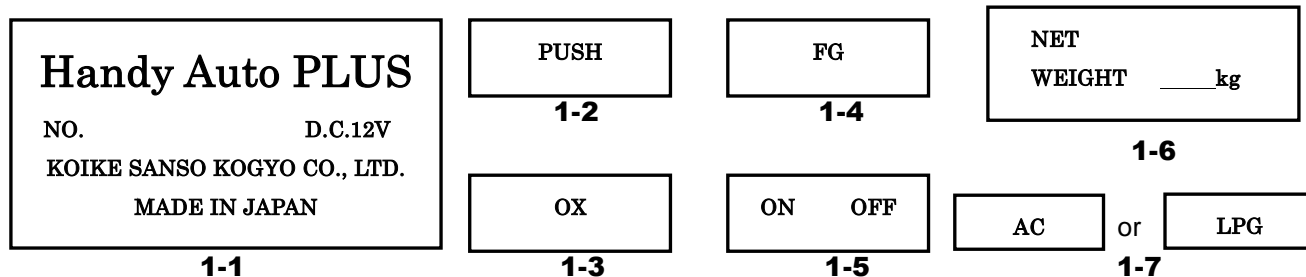
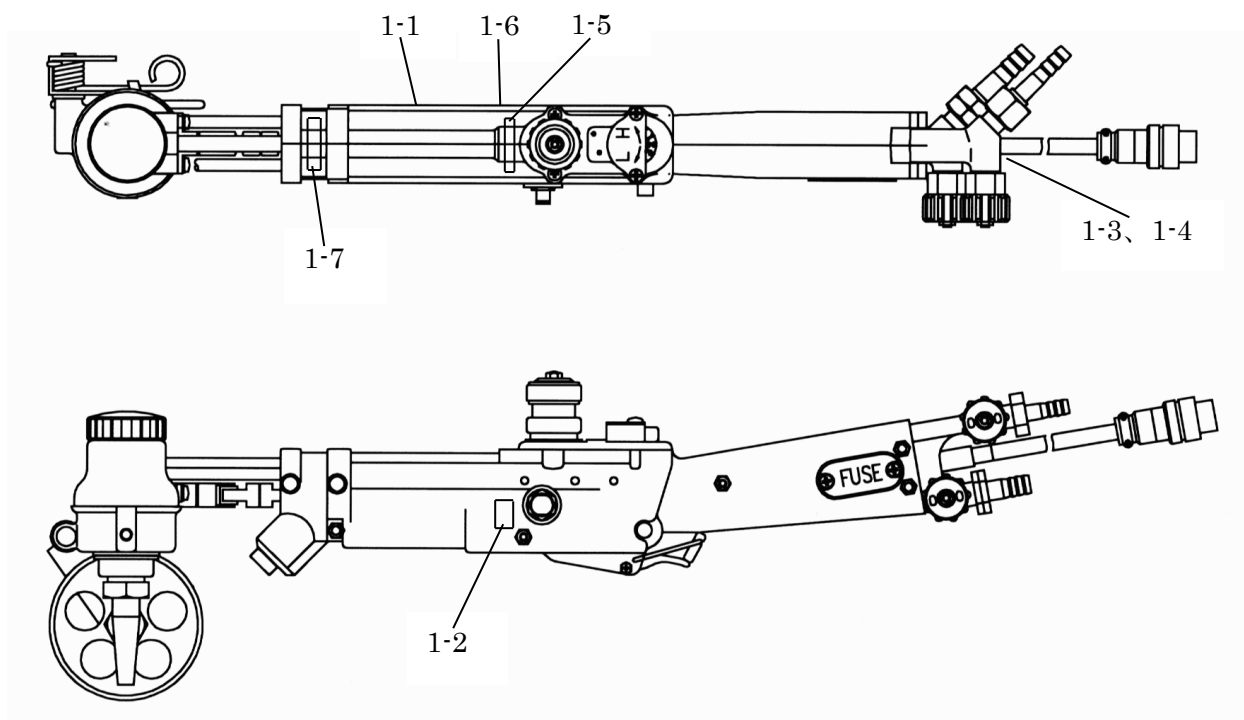

(Note) 1-7 Label   LPG label is stuck in the case of propane specification.  
 AC label is stuck in the case of acetylene specification.

## 3 Outline of machine

### 3.1 Features of machine

The "HANDY AUTO" is a portable automatic gas cutter developed on the basis of a novel idea for the purpose of automatization of portable cutters used in all work sites, incorporating their merits. The "HANDY AUTO" automatically moves as the wheel on the side of the tip turns. An operator can cut material in any shape by controlling the direction of the wheel. The machine can cut only flat material but also vertical material, angle bars, light section steel, round bars, pipes and deformed steel sheets.

Even a beginner can cut material smoothly by simple operation.

<Handy Auto II > is speed the one that turns the low speed and enabled the cut of  $\phi 7.87$  inch with a small circle cutting device, to expand the function of handy auto circle cut.

<Handy Auto Plus> leaves the characteristic of a Handy Auto and a Handy Auto II as it is, and incorporated an automatic ignition method by one-touch operation. The ignition subsequent to the 2nd time to bothersome flame adjustment unnecessary, being attached the flame adjustment memory it is.

### 3.2 Name and function of each section

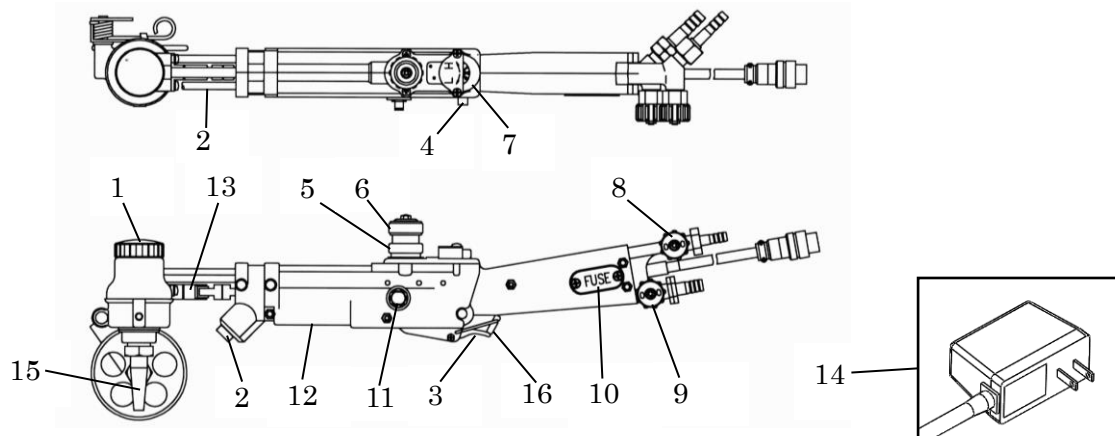

#### 1.Wheel locking knob

The wheel can change the position by  $360^\circ$  when the knob is loosened.

#### 2.Pilot nozzle

The pilot flame is formed by pulling an ignition lever.

#### 3.An ignition lever

By operating this lever, the high frequency is generated, and the pilot and preheating flame comes out.

#### 4.Rock/Release button of ignition lever

#### 5.Drive switch

The drive switch is interlocked with the cutting oxygen valve.

#### 6.Cutting oxygen valve

Turn the valve to feed cutting oxygen.

#### 7.Speed control knob

Turn the knob in the direction of H to move the machine quickly and to L to move slowly.

#### 8.Preheating oxygen valve

Turn the valve to feed preheating oxygen.

#### 9.Fuel gas valve

Turn the valve to feed fuel gas.

#### 10.Fuse

#### 11.Normal/reverse rotation changoover button switch

The switch changes the direction of the rotation and traveling.

#### 12.Motor

#### 13.Universal joint

#### 14.AC adapter

Insert the adapter into the power supply.

※ Adapters contain electronic components inside. dropping or hitting them can cause the internal electronic parts to break.

Please handle with care.

#### 15.Tip

#### 16.lever rock

### 3.3 Specifications

1.Weight(main unit)	:6.17pound
Handy auto kit	:17.42pound
2.Machine size	:20.67×2.76×5.83 inch (With standard wheel assembly)
3.Wheel drive	: Friction drive
4.Power source	:± 10%
5.Speed control method	: Transistor control
6.Cutting speed	:5.91~20.87 inch/min
7.R.P.M	:1.2r.p.m~4.2r.p.m
8.Cutting Thickness	:0.20~1.18 inch (by standard accessories)
9.Motor	: DC 12V 7200 r.p.m. reducer 1/400
Optional attachments	: Auxiliary wheel assembly
	: Beveling wheel assembly (22° ~45° )
	: Small circle cutting attachment ( φ 1.2 ~ φ 7.87 inch)
	: Guide lever
	: Large circle cutting attachment ( φ 4.7 ~ φ 19.7 inch)
	: Straight rail (19.7 inch)

## 4 Preparation for operation

### 4.1 Contents of package

Carefully take the machine out of the case.

First, please check your unit to make sure it is complete.

The following is a list of the standard parts you should receive.

#### STANDARD PACK

1) Main unit	:1 set
2) Standard wheel assembly	:1 set
3) Spanner	:1 pc
4) Fuse(mizett, 1A)	:2 pcs
5) Tip (102 or 106 type #0,1,2, one each)	:3 pcs

#### HANDY AUTO KIT

1) Main unit	:1 set
2) Standard wheel assembly	:1 set
3) Auxiliary wheel assembly	:1 set
4) Beveling wheel assembly	:1 set
5) Small circle cutting attachment	:1 set
6) Guide lever	:1 pc
7) Spanner	:1 pc
8) Fuse(mizett, 1A)	:2 pcs
9) Tip (102 or 106 type #0,1,2, one each)	:3 pcs
10) Steel carrying case	:1 pc
11) Tip cleaner	:1 pc

## 4.2 Machine assembly

1. Carefully take the machine out of its case.
2. Attach the primary hose to the gas distributor.

- (1) Oxygen hose (green) to the top position hose nipple  
 (2) Gas hose (red) to the bottom position hose nipple

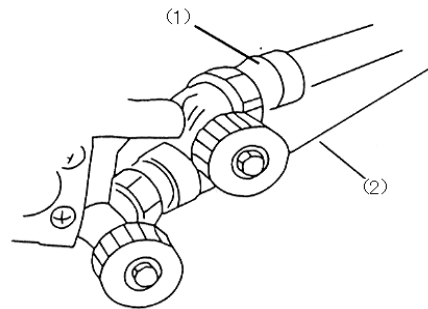

## 4.3 Preparation for operation

### 4.3.1 Connecting the power cable

1. Connect the metallic plug on the AC adapter side with the metallic receptacle on the machine side. Before connection, check that there is no foreign substances or dust.
2. The metal plugs are screw-threaded, therefore, fully tighten them so that they will not come loose during operation.

### 4.3.2 The method of setting the Pilot Burner

1. Take off the nozzle cover, and then set the Pilot Burner.  
 (Note) Take out two screws, and then the nozzle cover can be taken out. (Refer the following pictures.)

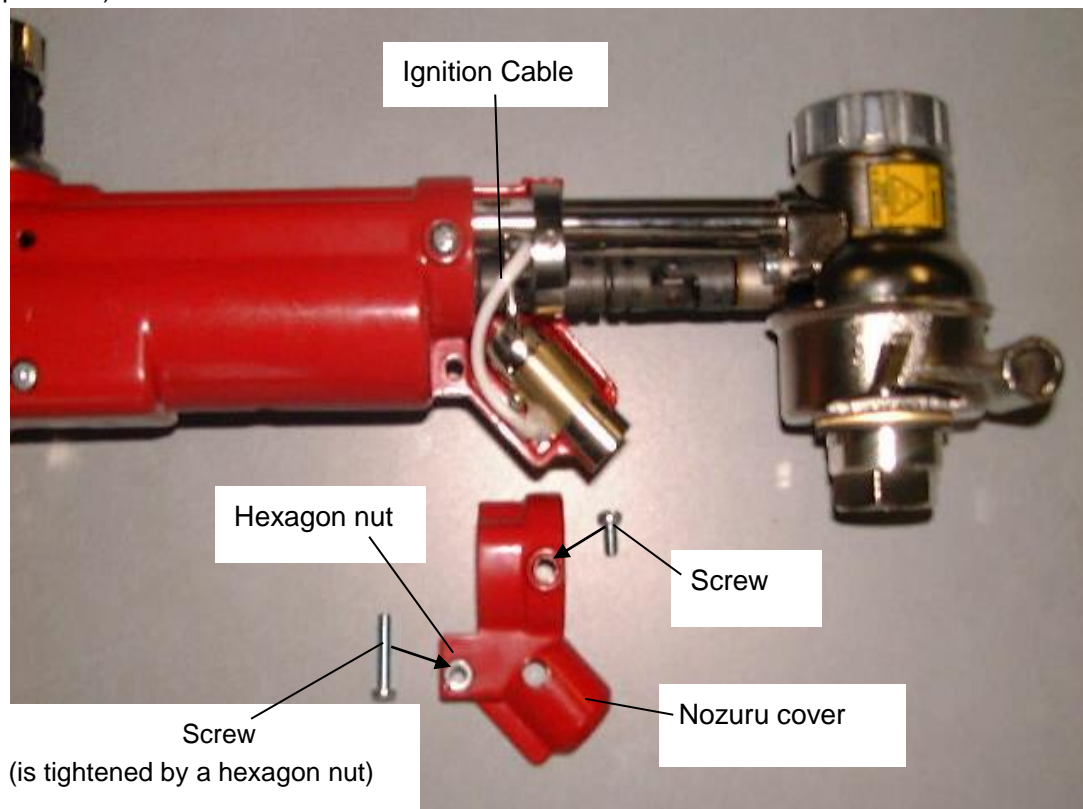

2. This Handy Auto PLUS is propane and also acetylene share machine.

Please confirm the position of the cover of the pilot nozzle before using.

(Refer the following drawings)

Please use this machine after adjusted it with the following method, in the case that the position relation between use gas and cover are not matching in case.

• for use Propane

- ( 1 ) Loosening a fixation screw the cover is moved fully in the direction of an arrow like a following sketch.
- ( 2 ) Please confirm that the V ditch for judgment is hiding with a cover.
- ( 3 ) Please confirm that the hole (air entrance) is not hiding with a cover edge.
- ( 4 ) Fix a screw after confirmation.

• for use Acetylene

- ( 1 ) Loosening a fixation screw the cover is moved fully in the direction of an arrow like a following sketch.
- ( 2 ) Please confirm that the V ditch for judgment is not covered with a cover.
- ( 3 ) Please confirm that the hole (air entrance) is half hiding with a cover edge.
- ( 4 ) Fix a screw after confirmation.

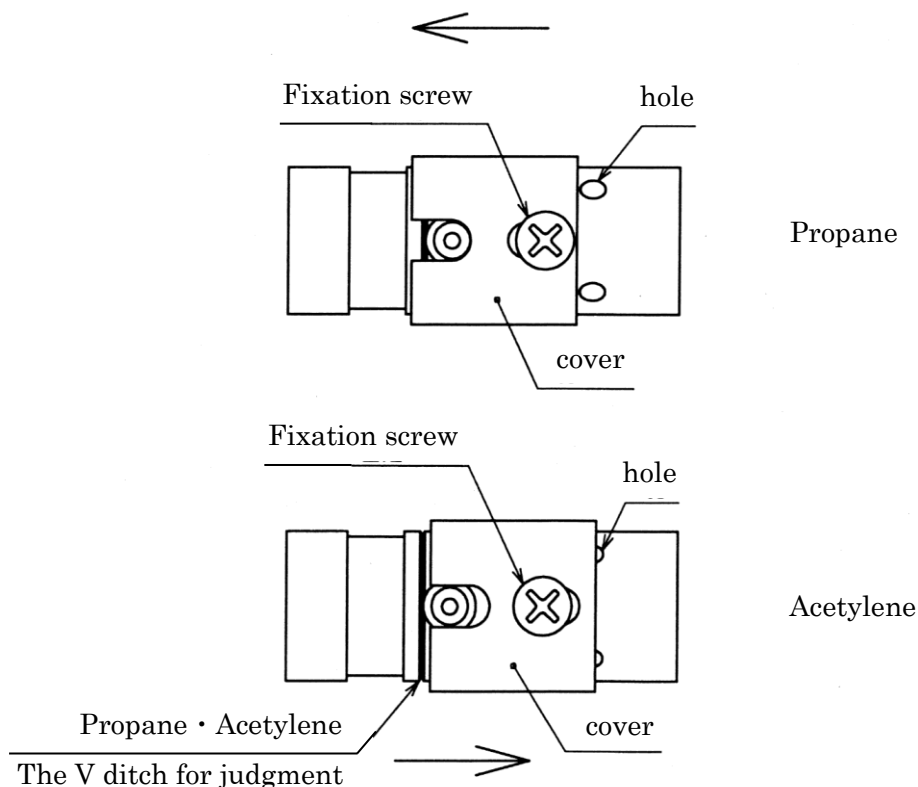

3. After completion of pilot burner setting, please install nozzle cover with screw

Attention: When installing nozzle cover, make sure ignition cable is not squeezed between the nozzle cover and the main body.

### 4.3.3 Connecting the tip

1. Select a proper tip according to the thickness of the steel plate and attach it to the torch.  
(To select a tip, refer to the table of Cutting Data.)
  - When fixing a tip to the torch, tighten the nut with the two wrenches attached.
  - If the tip is tightened excessively, it will be heated during cutting and tightened still more, making it difficult to remove the tip.
  - In addition, avoid damaging the taper of the tip since this may cause backfire.

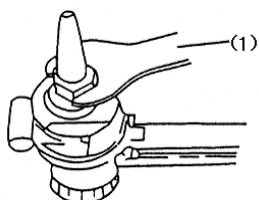

(1) Spanner

### 4.3.4 Installing the wheel

Insert the wheel bracket shaft into the gear cover. Pull up spring lever and hang it on the stopper.

- (1) Gear cover
- (2) Bracket shaft
- (3) Stopper
- (4) Spring

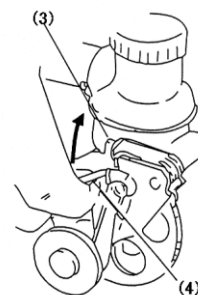
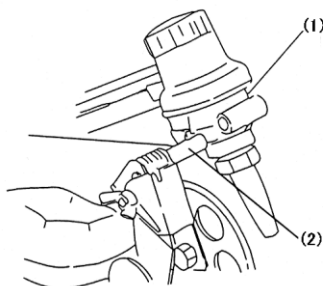

### 4.3.5 Fitting the wheel

As the wheel rotates a fully 360° from the center of the tip, all direction cutting is possible. Decide the position of the wheel as you like according to the material to be cut or for your positional comfort during the cutting operation.

To set the position of the wheel, loosen the wheel setting knob a little, set the position and tighten the knob up well.

- (1) Position setting knob
- (2) Direction for tightening
- (3) Direction for loosening

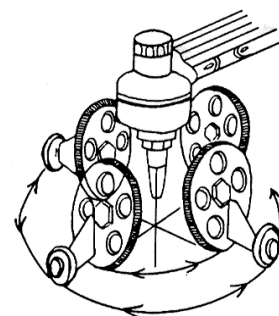
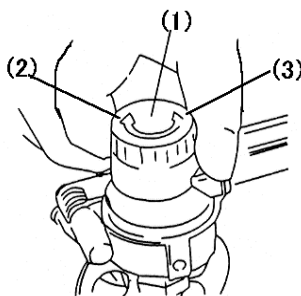



### 4.3.6 Cutting processes

Open the cutting oxygen valve more than 1/8 turn. This starts the motor, as the drive switch and the cutting oxygen valve are linked together. Both the drive switch and the cutting oxygen valve, however, can operate independently.

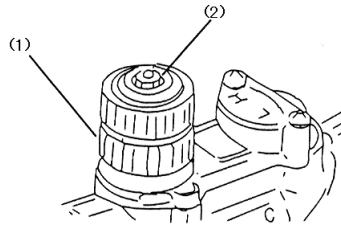
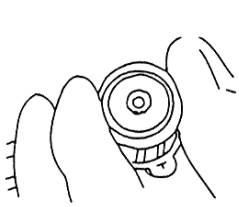

- (1) Drive switch
- (2) Cutting oxygen valve

### 4.3.7 Speed setting

Adjust the cutting speed with the speed adjustment knob according to the thickness of material immediately after the wheel has started rotating. Turn the knob toward the H to increase the cutting speed, and to L to decrease.

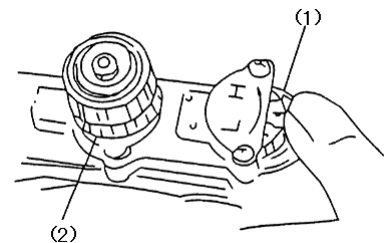

- (1) Speed adjustment knob
- (2) Drive switch

### 4.3.8 Changing over direction of motor rotation

To switch the direction of motor rotation, push and hold the button on the left side of the main unit until you hear a clink. Stop the motor beforehand, or the service life of the motor will be shortened, the fuse may blow, etc.

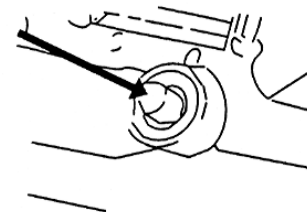

### 4.3.9 How to use guide roller

A guide roller is attached to the side of the wheel to stabilize the tip angle. The height of the guide roller can be adjusted by loosening the wing nut. Set it in the lower position for right-angle cutting. Select a proper height for bevel cutting in accordance with the angle to incline the machine and fix it with the wing nut.

- (1) Butterfly nut
- (2) Guide roller

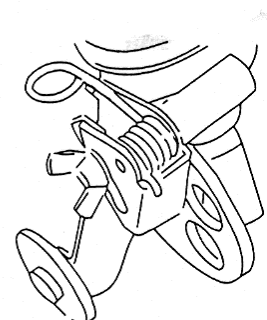
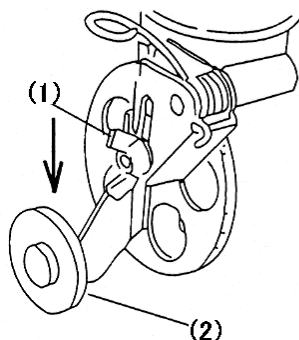

## 4.4 Optional attachments

### 4.4.1 Auxiliary wheel

This is used to add further stability to the cutting operation. To install, lift the guide roller of the square cutting attachment from the cutting material.

Then, fix the wheel with a butterfly nut.

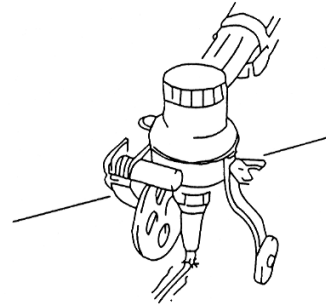

### 4.4.2 Beveling wheel

This is used for bevel cuts at an angle range of 22° -45°. To install, remove the square cutting attachment. Then loosen the guide roller fixing butterfly nut, adjust the position of the guide roller and set the bevel angle.

In bevel-cutting at a comparatively large angle, watch out for slip caused by dragging hoses or the condition of the material. For beveling, the use of the straight line cutting rail is recommended as this will give more stability than a hand-held operation.

For large angle beveling, use a tip one grade larger than that for straight cutting or pre-heat more thoroughly.

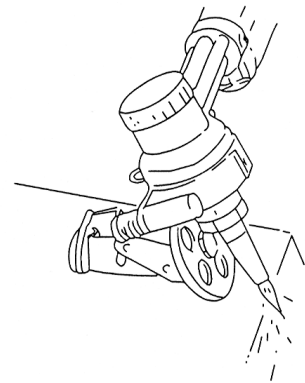

### 4.4.3 Small circle cutting attachment

This is used for cutting small circles of 1.2-7.87  $\phi$  inch

- 1) Remove the square cutting attachment.
- 2) Loosen the wheel setting knob.
- 3) Fasten the clutch knob to the gear cover firmly.
- 4) Loosening the radius setting knob, set the cutting radius and tighten the knob.
- 5) Put the drive switch to ON, and adjust the cutting speed.
- 6) The circle cutting attachment can be operated manually, by loosening the clutch knob. Decide the initial cutting position and set the attachment firmly in position.

During the circle cutting operation there may be fluctuations in the cutting speed. These are caused by hose drag, changes in the way or position the machine is held and the like being transmitted to rotation mechanism.

In cutting small circles with the small circle cutting attachment, be sure to loosen the wheel setting knob.

When cutting circles, always make sure the clutch knob is tightened.

When not cutting circles loosen or remove the clutch knob.

When you start a cut by piercing, open the cutting oxygen valve slowly after preheating to prevent cutting errors.

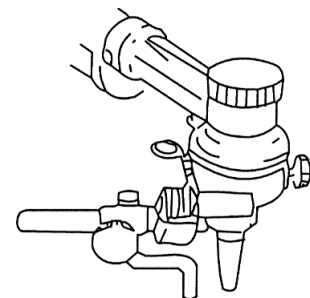

**【NOTE】**

- 1) Loosen the wheel position setting knob, in the case that you do circle cut by using a small circle cutting device.
- 2) Fix the clutch knob, during cut.
- 3) Loosen the clutch knob, when it does not use a small circle cutting device.  
It becomes the cause of malfunction when a bracket bar is moved while the knob is fixed.
- 4) Do not put in the hand, clothes etc. absolutely, because there are small gap between the radius adjustment bar and machine body when cutting small circle. Please pay attention sufficient so as not to be put.

**<Setting the cut speed>**

- The cutting speed (R.P.M.) is different by the diameter and the plate thickness of cut piece.
- The specification range of the small circle cutting device of Handy Auto II are 1.2rpm~4.2rpm.
- Set the cutting speed by using the following cutting chart.

thickness [mm] speed [mm/min]		5	5~10	10~15	15~30
		660	550~660	490~550	400~490
diameter	30	-	-	-	4.24
	40	-	-	3.90	3.18
	50	4.20	3.50	3.12	2.55
	60	3.50	2.92	2.60	2.12
	70	3.00	2.50	2.23	1.82
	80	2.63	2.19	1.95	1.59
	90	2.33	1.95	1.73	1.41
	100	2.10	1.75	1.56	1.27
	120	1.75	1.46	1.30	1.06
	140	1.50	1.25	1.11	-
	160	1.31	1.09	-	-
	180	1.17	-	-	-
200	1.05	-	-	-	

This chart calculated the turn number based on the speed of a tip ability chart in the case of using straight type of cutting tip. Therefore, the turn number to cut diameter changes, because cut speed changes in the case that a divergent tip is used.

And the above turn number is changed by the condition of cutting material, set pressure of gas and etc. Observe the condition of cut well and decide cut speed.

**4.4.4 Straight line cutting rail**

This is used for precise straight line cutting.

Loosen the butterfly nut and adjust the position of the magnet along the slot in the rail bracket according to the size of the material.

Set the rail parallel with the cutting line

Put the guide roller in the groove on the rail.

Be careful to maintain a horizontal grip position. Otherwise the guide roller may come off the groove, Spoiling the cut surface.

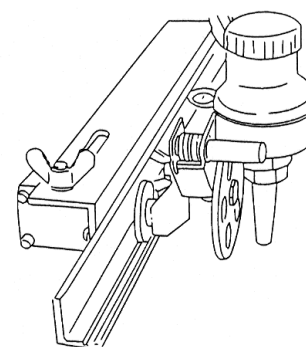

#### 4.4.5 Manual guide lever

This is used to get further stability during the cutting operation. The use in combination with an auxiliary wheel is better.

Remove the wheel setting knob. Insert the guide lever into position.

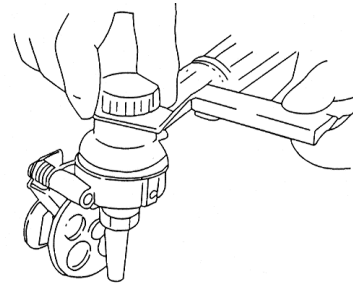

#### 4.4.6 Large circle cutting attachment

Large circle cutting attachment(  $\phi$  4.7 –  $\phi$  19.7inch)

- (1)Wheel position fixing knob
- (2)Stopper
- (3)Adjustable holder
- (4)Radius fixing bolt
- (5)Standard wheel
- (6)Guide roller
- (7)Magnet
- (8)19.7 inch diameter Bar

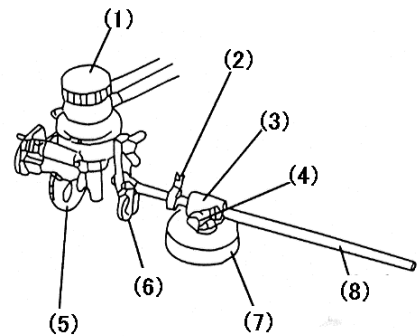

##### ● Usage

- 1)Be sure to use the standard wheel for cutting out large circles. Raise the guide roller so that it will not touch the Steel sheet.
- 2)Fix the 19.7 inch diameter bar to the main unit with a wing bolt.
- 3)Loosen the wheel position fixing knob.

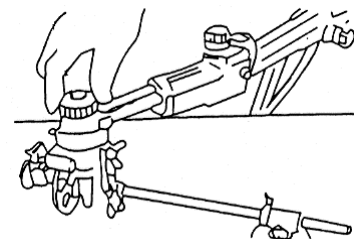
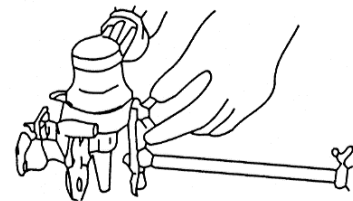

- 4) Use a magnet center to set the magnet in the center of the circle to be cut.
- 5) Set the adjustable holder in the magnet, loosen the radius fixing bolt, and adjust the cutting radius before fixing.
- ⊙ Use a stopper for in-feed cutting. When a disc is a product, set the stopper as shown in the photo, and when the hole is to be made as a product, set the stopper on the side opposite to the side shown in the photo with respect to the adjustable holder.
- 6) Turn on the drive switch, and adjust the speed.

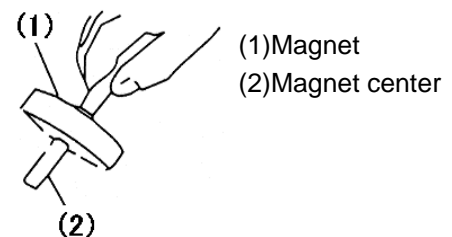

- 7) Raise the main unit (standard wheel) from the steel sheet to move the main unit to any desired point on the circumference. Determine the cutting start position in this way.
- 8) Operation hereafter is the same as the line cutting operation. Open the Jox valve, and the standard wheel is driven automatically, to start circle cutting.

● Notice

- 1) Loosen the wheel position fixing knob to cut out circles with the large circle cutting attachment.
- 2) The drive wheel may go beyond a steel sheet when cutting its edge. Therefore, use a support roller as a manual guide for cutting.
- 3) Remove the support roller for cutting out circles of 5.9 inch diameter or less.

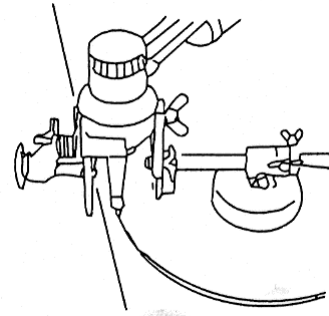

## 5 Cutting operation



### 5.1 Safety measures prior to operation



#### 5.1.1 Precautions for handling AC adapter

1. The AC adapter cannot be repaired. When it has failed, replace it with a new one.
2. The case of the AC adapter is made from synthetic resin.
  - 1) Do not place the case in a hot place.
  - 2) Do not drop a heavy object onto the case.
  - 3) Make sure that the supply voltage is correct. The operating voltage is 100~240 VAC 10%.

#### 5.1.2 Selection of tip

Referring to the Cutting Data, select the suitable tip according to the plate thickness.

For a heavily rusted plate or for a bevel cutting angle of more than 20°, select the tip one grade higher than the one shown in the Cutting Data.

#### 5.1.3 Traveling direction changeover switch



1. The traveling direction changeover switch on the machine is used to change forward/backward movement for linear cutting and clockwise/counterclockwise turning for circular cutting. Check the traveling direction or turning direction before cutting.
2. To change the traveling direction, return the drive knob to the stop position. Then after the machine has stopped completely, change the traveling direction.

**Note:** Before turning on the power, be sure to check that the drive knob is on the stop position. If the drive knob is on, it is dangerous to start the machine.

## 5.2 Ignition, Extinguishes flame and Flame adjustment

### 5.2.1 Gas supply

- (1) Connect the hoses of Oxygen and Gas to Handy Auto PULS.
- (2) Set the Gas pressure.
 

OX	:Set a little higher pressure against the required pressure of using tip plus 0.1 MPA (15PSI).
Propane	:Set to 0.04~0.06Mpa (6~8.5PSI)
Acetylene	:Set to 0.04~0.06Mpa (6~8.5PSI)
- (3) Check the gas leakage of connection part and confirm that there is not a gas leakage.

### 5.2.2 Procedure of ignition

- (1) Turn off the valve of POX and FG.
- (2) Pull fully an ignition lever located under the gas distribution unit of the Handy Auto.
  - The gas flow sound from nozzle and the discharge sound from igniter are observed.
  - In the case of first ignition, there are air in the hose instead of gas. Under this condition, the ignition is not succeeded.
  - In the case of this condition, open the valve of gas and blow out it a little with pull an ignition lever after check that there are no fire surroundings.

- (Blowing out of gas in long time is dangerous. Repeat two or three times short blow.)
- (3) When the pilot flame was generated, open the Gas valve on rear distribution unit. And the pilot flame fires Gas from tip.
  - (4) When the tip was fired, release ignition lever.  
Although pilot gas and ignition stop the FG valve and POX valve of the gas distribution unit adjust it to a proper flame to the tip with the FG valve and POX valve of rear distribution, because they are holding ON condition. (Refer 5.2.3 Flame adjustment)
  - (5) The flame stops changing even if the hand and thing touch the valve unpreparedness about, if turn it to the right 90 degree in the condition which the handle of the FG valve and also POX valve of rear distribution are pulled in the front, if the initial flame adjustment ends. (Memory function)
  - (6) Ignition subsequent to the 2nd time.
    - When ignition lever is pulled fully the preheat flame that was adjusted by the FG valve and also POX valve of rear distribution was fired at the same time as ignition to pilot.
    - If the preheating flame is set once, as for in the 2nd after the normal preheating flame is formed just pulling a lever.
    - When the ignition lever released the pilot flame becomes OFF and the preheat flame is held.

### 5.2.3 Flame adjustment

- (1) Opening the preheat valve gradually right after ignition and find the proper length of white point in a standard flame.  
(Length of the white point is 0.2~0.24 inch and to be out evenly desirable.)
- (2) Open the oxygen valve fully. Do readjustment when the flame converted it. The disorder of the cutting oxygen flow exerts an influence on the quality of a section. Clean the hole of the tip while sending cut oxygen, with the cleaning needle of the belonging that fit to hole diameter at the time of defectiveness.

Natural flame ensures a good quality cut surface. (Oxidized flames may be used for bevel cutting.)  
The oxidized flame shortens the cutting oxygen flow, causing slug deposition or melting the upper edge of the cut surface. Excessively high cutting oxygen pressure will cause the same effect.

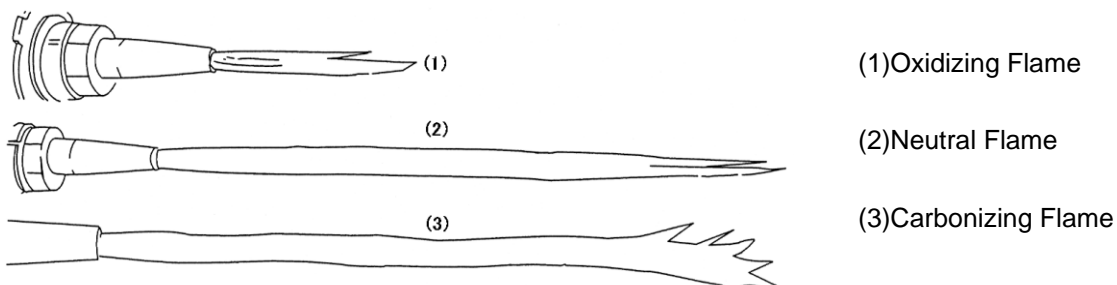

(1)Oxidizing Flame

(2)Neutral Flame

(3)Carbonizing Flame

### 5.2.4 Preheating

For preheating, hold the grip with your right hand to support the HANDY AUTO and hold the cutting oxygen valve with the thumb and forefinger of the left hand to stabilize the HANDY AUTO.

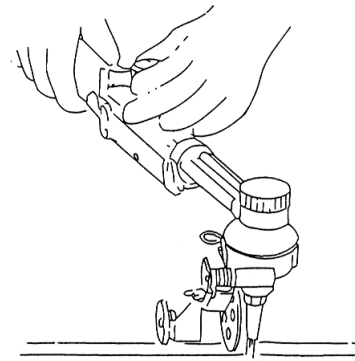

### 5.2.5 Procedure of extinguishing flame

By pushing the release push button that was attached in the right side of lever toward the lever-side the FG valve and also POX valve inside the distribution valve unit become OFF and the preheat flame extinguishes.

### 5.2.6 Only pilot flame ON/OFF

Close the fuel gas valve and preheat oxygen valve that are in a rear distribution unit.  
Pull an ignition lever fully.

### 5.2.7 Photograph of ignition lever unit.

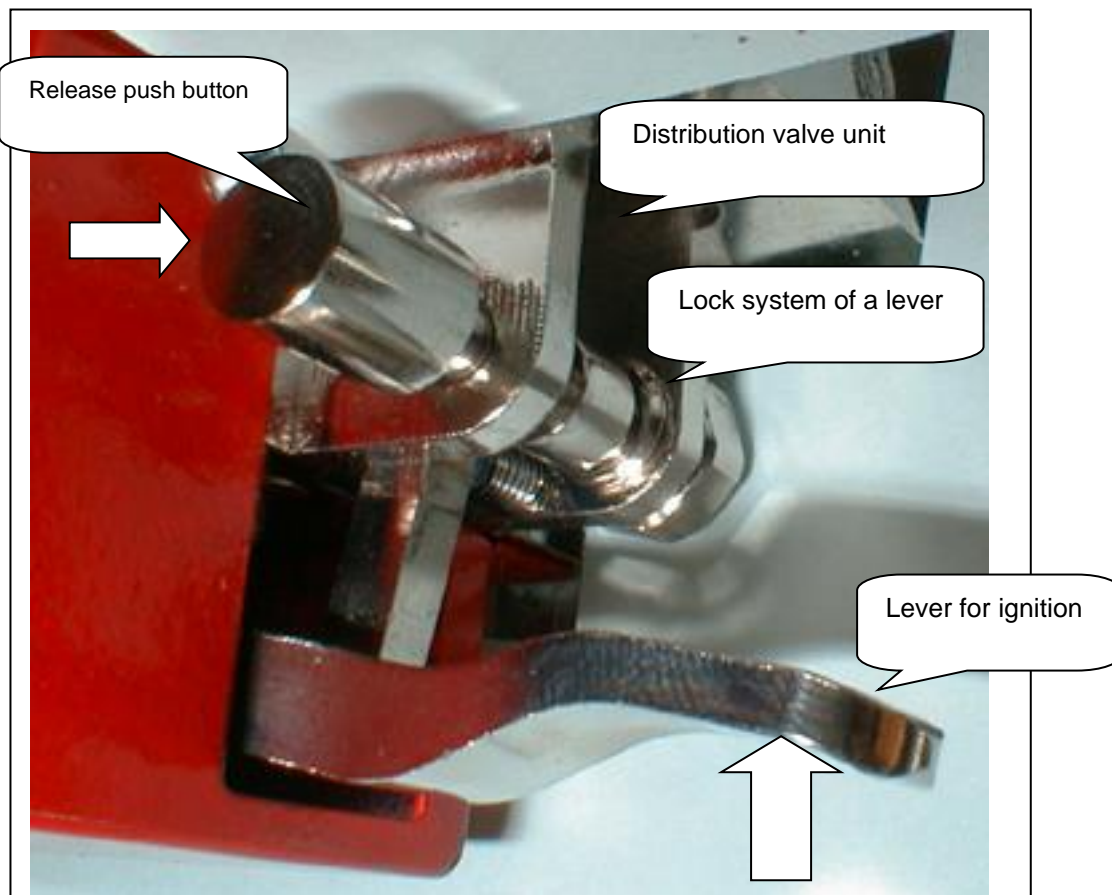



## 5.2.8 Lock system of the lever for ignition

Make sure that the safety lock is set in an ignition lever when the machine is not used and please do so that it can not be operated.

Refer to the following drawings for the lock system of lever.

**At the time of the storage or rest.**

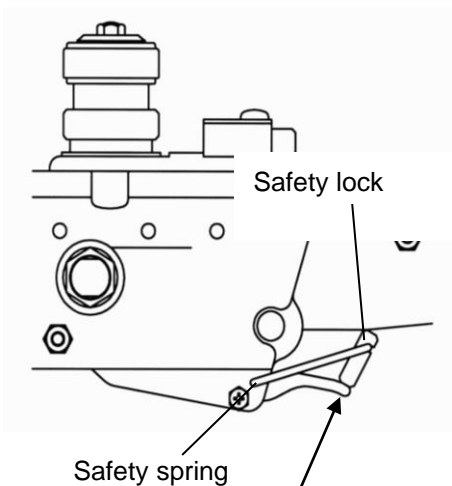

Safety lock is hooked to an ignition lever.

**At the time of normal use**

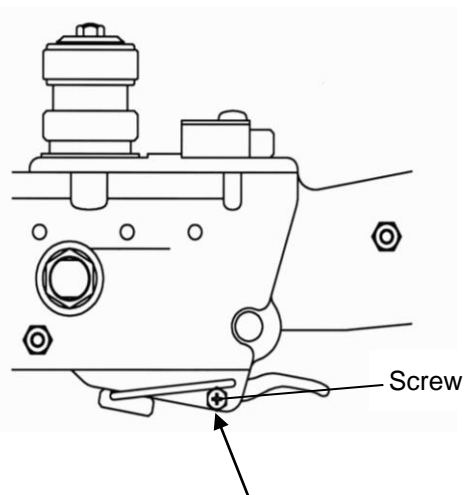

Fix a safety spring by bringing it on to a screw.



**Make sure that the gas valve is closed, when you do not use it or you part from the machine. Also, Lock a safety lock so that the ignition lever can not be operated.**

**(The gas leakage that depends suddenly is very dangerous. There is the possibility that is connected to an important accident.)**

## 5.2.9 Lock system of valve

Handy Auto PLUS prevents (1) (2) by the lock system of a valve.

- (1) The gas leakage by the sudden valve operation that is easy to occur to the exception at the time of operation is prevented preventively.
- (2) The flow change by a sudden valve operation is prevented after adjustment completion.

Refer to the following drawings for the lock system of valve.

**At the time of adjustment**

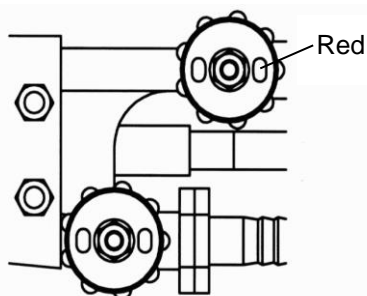

Condition of as it is

**At the time of a rest, After adjustment completion**

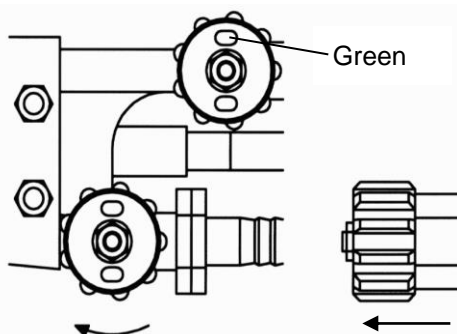

Pull a handle to the arrow side, and then turn it to the right.

### 5.3 Cutting and piercing method

1. Cut in from the end of steel plate.
2. Pierce steel plate before cutting.
3. Drill a hole before cutting.

#### ■ Piercing method

- 1) Ignite and adjust the flame.
- 2) Thoroughly preheat the cut-in point until it is white hot.
- 3) Open the cutting oxygen valve to pierce the steel plate. The tip should be about 0.6-0.79 inch from the plate to prevent slag from splashing onto the tip and adhering there, which will shorten the working life of the tip.
- 4) Piercing starting from the middle of the material is not recommended, since the result heat exposure will spoil the durability of the wheel. If such piercing is unavoidable, turn the drive switch on independently to rotate the wheel and start preheating, lifting the main unit up a little to prevent the heat affecting the wheel.

After cutting like this, the motor may not stop sometimes even after cutting is finished. This is not a fault but is caused by the valve not having been opened fully. The motor will stop, when the drive switch is tightened.

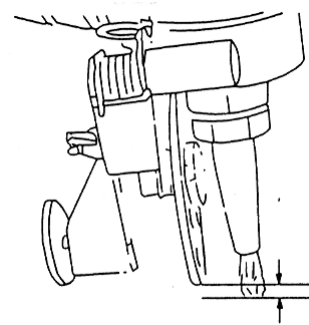

## 5.4 Procedures for starting cutting operation and extinguishing the flame

1. Align the tip with the cutting start point, ignite, and then adjust the flame.
  2. Sufficiently preheat the cutting start point.
  3. After heating, open the oxygen valve by turning it more than 1/8 turn, and the motor switch will be turned on, starting automatic cutting. When the valve opening angle is too small at that time, cutting operation will not be interlocked with the motor switch. When cutting an approx. 6 mm thick plate at a high oxygen pressure, the valve opening must be adjusted; therefore the motor switch may not be turned on. (Refer to the Cutting Data for pressure setting.)
  4. Carefully check the cutting condition, and control the cutting speed with the speed adjuster. For the cutting speed, refer to the Cutting Data.
  5. Extinguish the flame after cutting as follows:
    - 1) Close the cutting oxygen valve.
    - 2) Push the release button that is attached in the right side of lever on a lever side.
- Note) Close the preheat oxygen valve, preheat gas valve, in the case that no cutting work in succession. Also, lock a safety lock so that an ignition lever can not be operated suddenly.
- \*After, it becomes the repetition from item (1).

6. The guide roller is designed for stable and even cutting operation. But for preventing unstable tip movement such as might be caused by hose drag or the cutting travel, use of both hands, with the left hand supporting the cutting oxygen valve or the motor unit, when switching off the cutting oxygen.

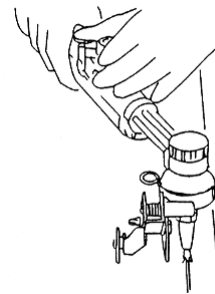

### 5.4.1. Thin plate cutting

When you cut a thin plate, 6mm thick for instance, adjust for a slightly weak flame, after selecting the tip size and the pressure suitable for the job according to the cutting data. Tilt the tip top forward slightly, then start the cutting operation.

Cutting with a too high cutting oxygen pressure or with too much preheating will cause incomplete separation of the material, or cause slag to stick on the lower edge of the cut.

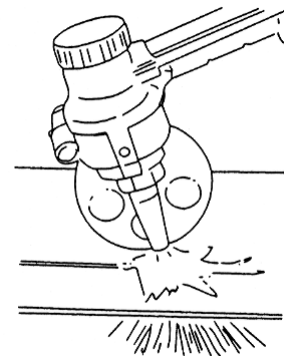

### 5.4.2. Bevel cutting

For bevel cutting, use a tip one grade above that for the specified thickness for straight cuts in the same thickness of plate in the cutting data, with a somewhat strong preheat flame and set the speed 20-30% lower.

The 0-22° bevel cutting is possible with the standard wheel, and the beveling wheel range is 22-45° . Insufficient preheating causes a cut surface in bevel cutting. Reselect the tip, readjusting the preheat and speed

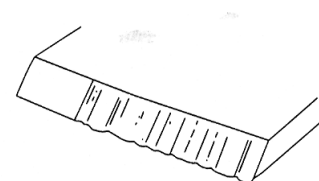

## 5.5 Safety measures against backfire and flashback

### 5.5.1 Prevention of backfire

Backfires may cause serious accidents or fires. Be careful to prevent such disaster. When a backfire occurs, find the cause and inspect and maintain the machine correctly before using the machine again.

The following are causes of backfire:

- 1) Improper gas pressure adjustment.
- 2) Overheated tip.
- 3) Slag clogged in tip.
- 4) Damage to the tapered section of the tip or torch will cause backfire.

### 5.5.2 Prevention of flashback

Flashback could cause fire and break the machine. Should there be a hissing sound in the torch, quickly take the following action:

- 1) Close the preheating oxygen valve.
- 2) Close the fuel gas valve.
- 3) Close the cutting oxygen valve.

Should flashback occur, find the cause and take appropriate action before using the machine again.

## 6 Maintenance and inspection

Refer to the following for inspection and maintenance of the machine and use the machine under the best operating conditions at all times.

### 6.1.Wheel Maintenance

As wheels are made of stainless steel (SUS-27), they are of rust-proof and have high heat and slag resistance. Even if slag sticks to the wheel, you can easily take it off with a wire brush or the like. Carry out periodic inspection and maintenance to prevent knocking or slag-sticking which may cause faulty power transmission to the wheel.

When the wheel knurls, become worn, replace the wheel. A worn wheel may cause slip and prevent operation.

### 6.2.Tip Maintenance

The tip used for the Handy Auto is designed for high durability combined with high safety. To maintain cutting quality, follow the correct instructions on maintenance and handling.

- (1) In piercing, lift the machine body up a little to prevent damage caused by the flame being deflected upwards.
- (2) Clean the orifice of the tip very carefully with a tip cleaner of the correct size.
- (3) Be careful not to damage the tapered seating section.

Replace the tip when the following occur.

- a. Even after cleaning, the cutting oxygen jet does not extend straight.
- b. The cutting oxygen jet flares at its end.
- c. During the cutting operation, clicking sounds are heard within the tip.
- d. Gas leaks from the fixing nut and burns.
- e. Pre-head flames are extremely uneven.

## 6.3. Lubrication

For greater safety, the Handy Auto has been designed so that lubrication is not necessary.

## 6.4 Inspection of the gas leakage

There is the possibility that the gas connection part gets loose by the vibration, thermal expansion etc. in use.

Please confirm the gas leakage of the connection part, before use.

Please confirm even the gas leakage of the pilot burner and tip top part.

## 7 Trouble shooting

1) Motor does not run.

Possible Cause	Procedure	Remedy
1) No electrical power.	Check power circuit.	
2) Faulty fuse.	Check fuse.	Replace.
3) Faulty drive switch.	Check that clicking sound is heard by turning that the drive switch to the full extend. (This sound indicates the switch is not faulty.)	Repair.
4) Broken power cord.		Repair or replace.

2) Motor does not run. (Power is on.)

Possible Cause	Procedure	Remedy
Foreign matter on the beveling gears.	Check by removing the fixing knob and the head cover.	Clean.

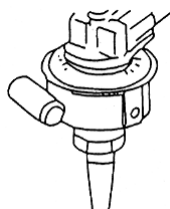

3) Motor runs but rotation is not transferred to the universal joint.

Possible Cause	Procedure	Remedy
Screw holding the speed reducer shaft to the universal joint is loose.		Tighten the screw.

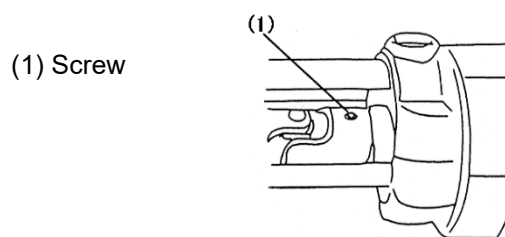

4) Beveling gear (Large) rotates but rotation is not transferred to the wheel or slipping and knocking occurs.

Possible Cause	Procedure	Remedy
1)Slag between the drive wheel and the beveling gear.		Clean

5) Wheel rotates but speed cannot be adjusted.

Possible Cause	Procedure	Remedy
Faulty speed adjuster or transistor.		Repair or replace.

## 8 Wiring diagram

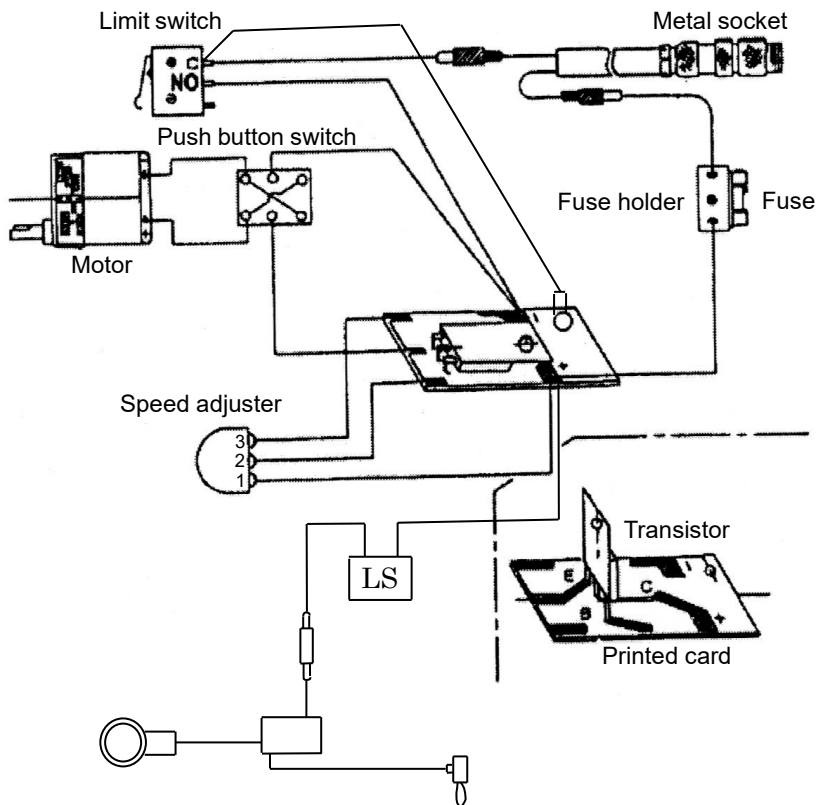

## 9 Electrical diagram

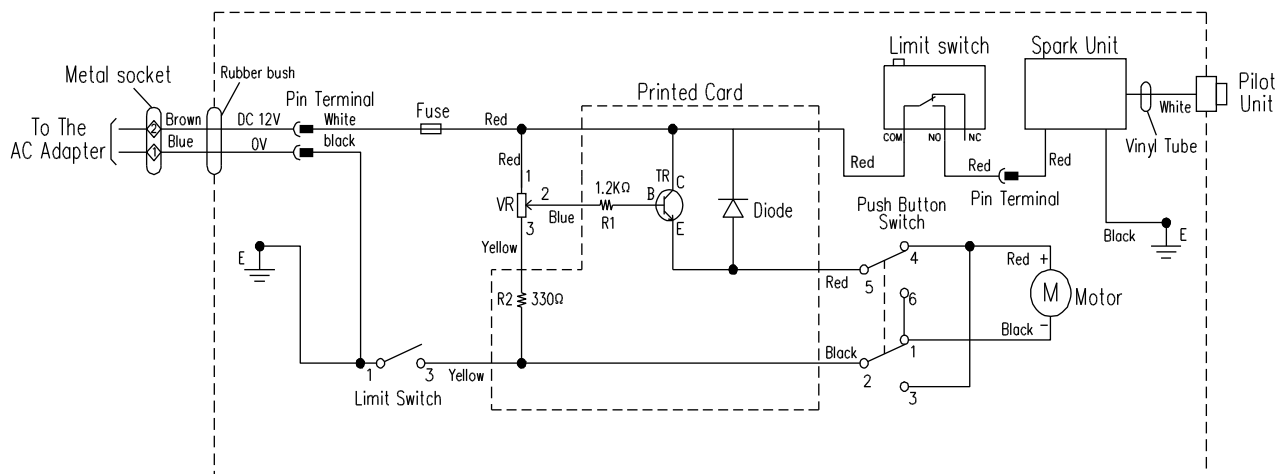

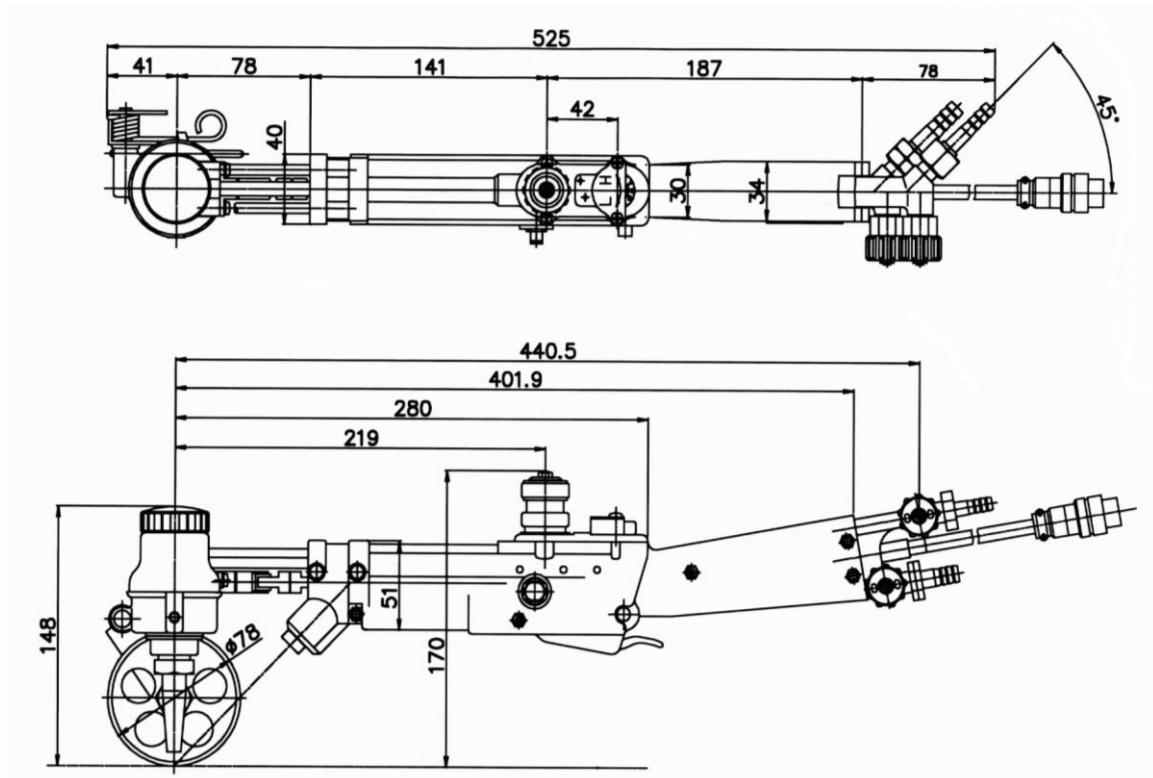
**10 Assembly drawing of Handy Auto PLUS**

# 11 Parts list

## 11.1 Main units

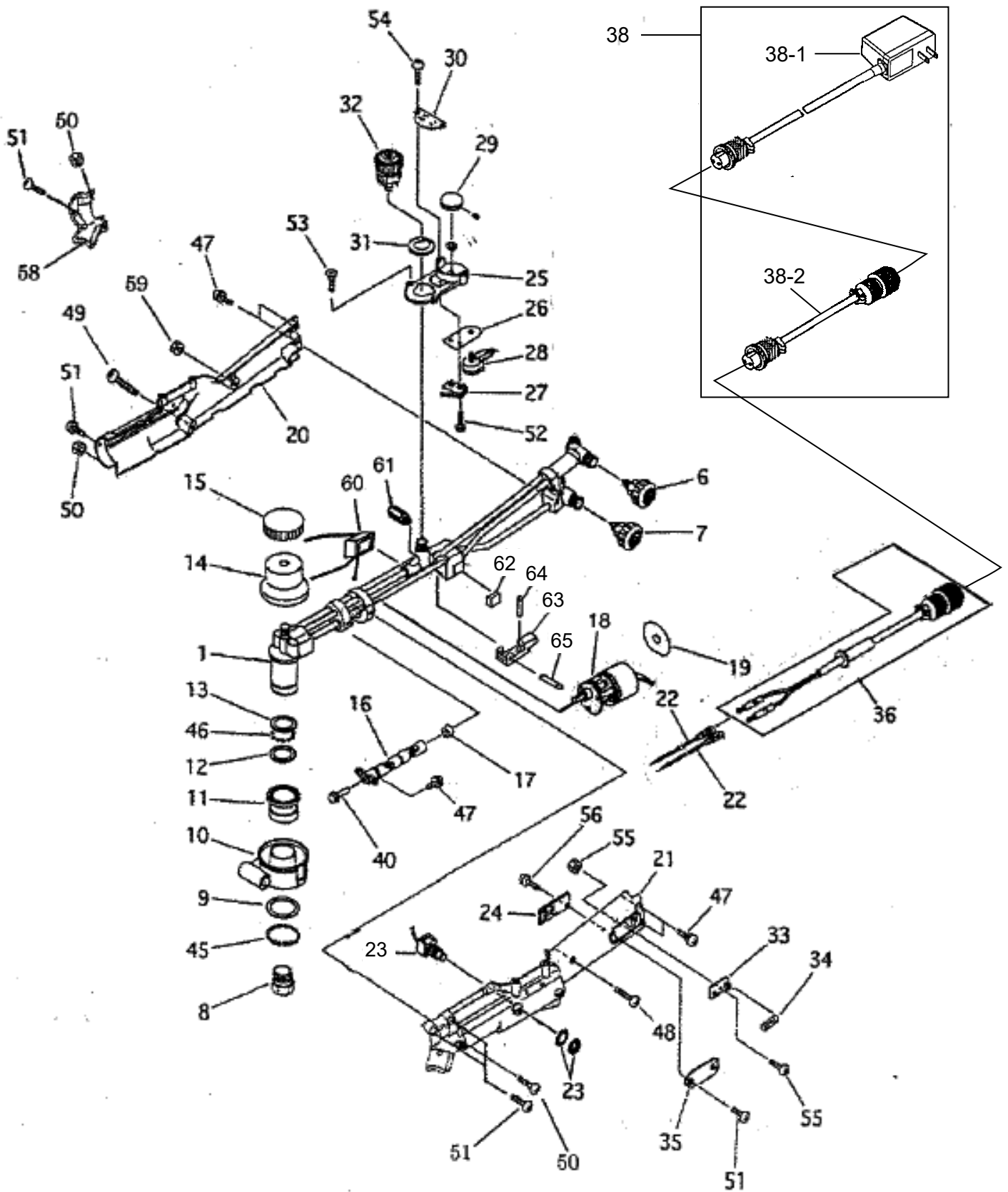



## Main units

Item No.	Part name	Q'ty	Stock No.	Remarks
1	Torch	1	61001952	2A01357A0
6	Valve for preheat oxygen	1	80015777	Blue
7	Valve for gas	1	80015778	Red
8	Tip fixing nut	1	60015032	
9	Torch head collar	1	60030003	
10	Gear cover	1	60030004	
11	Bevel gear	1	60030007	With DU bush
12	Thrust collar (Lower side)	1	60030008	
13	Thrust collar (Upper side)	1	60030009	
14	Torch head cover	1	60030005	
15	Position setting knob	1	60030006	
16	Universal joint	1	60030010	
17	Reduction gear collar	1	60030097	
18	Motor with speed reduction gear	1	61005294	
19	Motor insulating plate	1	60030038	
20	Main unit cover (right)	1	61001724	
21	Main unit cover (left)	1	61001723	
22	Mid way terminal	1	60030028	
23	Press button switch	1	61002003	
24	Printed circuit card	1	60030064	
25	Limit switch cover	1	20536556	
26	Limit switch insulating cover	1	60030017	
27	Limit switch	1	60030023	
28	Speed adjuster	1	20535930	
29	Speed adjuster knob	1	20537108	With screw
30	Speed adjuster cover	1	60030016	
31	Limit switch top	1	60030012	
32	Jet oxygen valve with knob	1	60030013	
33	Fuse holder	1	60030026	
34	Fuse	1	60030027	
35	Fuse cover	1	60030018	
36	Metal socket with cord	1	61004650	
38	AC adapter	1	20543811	※2
38-1	HA AC Adapter Cable	1	20543802	★
38-2	HA AC adapter extension cable	1	20543570	※1 ★
40	Bevel gear (S)	1	60030062	
45	Stop ring	1	6B530280	ISTW-28
46	Steel ball	1	60030181	32Pcs/1Set
47	Screw	1	6C530410	SP-4x10,With WS
48	Screw	1	6C530430	SP-4x30,With WS
49	Screw	1	6C520435	SP-4x35
50	Screw	1	6C610418	SP-4x18,With NH
51	Screw	4	6C520408	SP-4x8
52	Screw	2	6C520210	SP-2x10
53	Screw	2	6C500408	SF-4x8
54	Screw	2	6C520408	SP-4x8
55	Screw	1	6C610306	SP-3x6,With NH
56	Screw	1	6C520406	SP-4x6
58	Nozzle cover	1	61001725	
59	Hexagon nut	1	6D010040	NH-4
60	Ignition Transformer	1	61001726	
61	Support	1	64000055	PLSBWRK7-20
62	Micro limit switch	1	64000147	
63	Lever	1	80009299	
64	Pin	1	80009325	
65	Wave spring pin	1	6B400003	PS-3x17

※1 Please do not connect 20543570 together to extend the cable length.

※2 Adapters contain electronic components inside. dropping or hitting them can cause the internal electronic parts to break. Please handle with care.

## 11.2 Option units

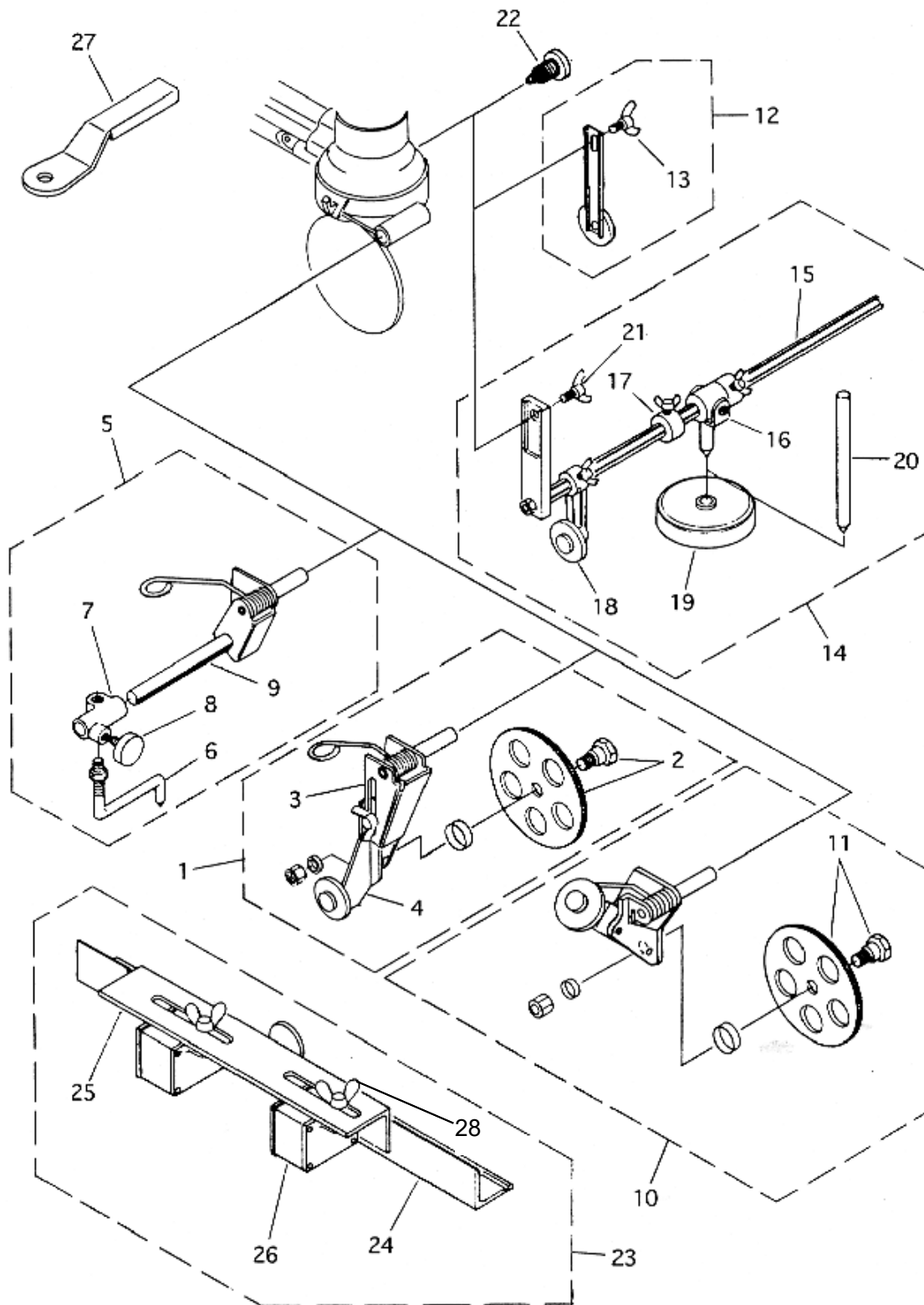

## Option units

Item No.	Part name	Q'ty	Stock No.	Remarks
1	Standard wheel assembly	1	60030100	
2	Drive wheel (3inch diameter)	1	60030107	With shaft and nut
3	Standard wheel bracket	1	60030108	
4	Guide roller	1	60030109	
5	Small circle cutting attachment assembly	1	61001597	HAP
6	Centering needle	1	61001556	HAP
7	Centering needle holder	1	60030113	
8	Radius setting knob	1	60030114	
9	Bracket bar assembly	1	61001599	HAP
10	Beveling wheel assembly	1	60030102	
11	Beveling wheel	1	60030110	With shaft and nut
12	Auxiliary wheel assembly	1	60030101	
13	Wing bolt	1	60030126	
14	Large circle cutting attachment assembly	1	60030106	
15	Bar (19.7inch diameter)	1	60030120	
16	Free holder	1	60030121	
17	Stop collar	1	60030122	With wing bolt
18	Support roller	1	60038763	★
19	Magnet	1	60030124	
20	Magnet center	1	60030125	
21	Wing bolt	1	60030127	
22	Clutch knob	1	60030115	
23	Straight rail assembly	1	60030104	
24	Rail	1	60030117	
25	Rail bracket	1	60030118	
26	Magnet	2	61001160	
27	Guide lever	1	60030105	
28	Wing bolt	2	6C120510	BS-5×10

### 11.3 Pilot unit Ass'y

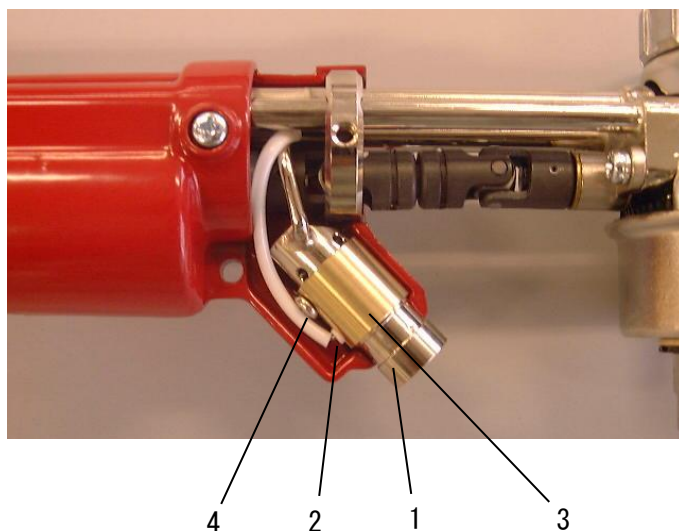

Item	Parts Name	Q'ty	Stock No.	Remarks
1	Mixing pipe	1	80009322	
2	Electrode	1	80009324	
3	Cover	1	80009328	
4	Set screw	1	6C520305	SP-3x5

### 11.4 Safety lock ass'y

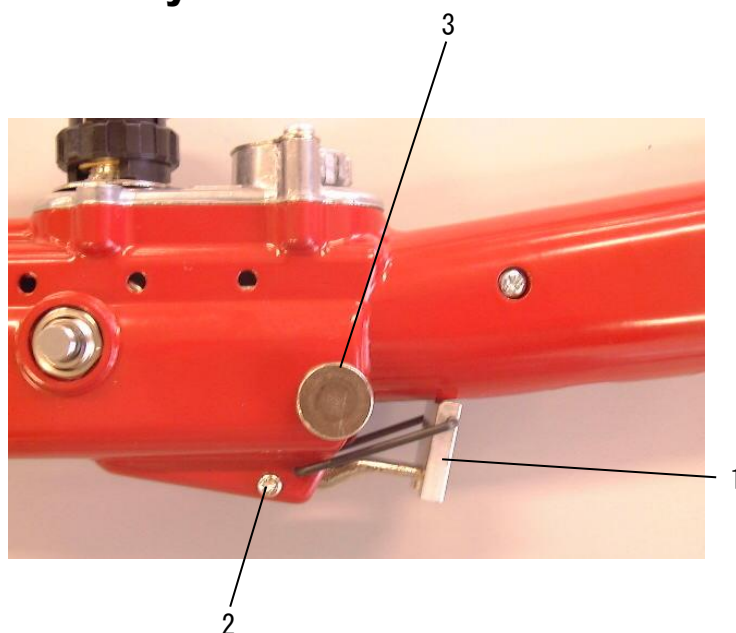

Item	Parts Name	Q'ty	Stock No.	Remarks
1	Safety lock ass'y	1	61002199	
2	Set screw	1	6C520303	SP-3x3
3	Lock button	1	80009301	

## 12 Cutting data

### 102(STANDARD SPEED) For Acetylene

PLATE THICKNESS (inches)	TIP SIZE	CUTTING SPEED (in/min)	OXYGEN PRESSURE (kg/c m <sup>2</sup> ) / (Mpa)		FUEL GAS PRESSURE (kg/c m <sup>2</sup> ) / (Mpa)	KERF WIDTH (inches)
			CUTTING	PREHEAT		
1/8	00	27	1.5 / 0.15	1.5 / 0.15	0.2 / 0.02	0.04
1/4	0	24	2.0 / 0.2	2.0 / 0.2	0.2 / 0.02	0.05
3/8	0	22	2.0 / 0.2	2.0 / 0.2	0.2 / 0.02	0.06
1/2	1	21	2.5 / 0.25	2.5 / 0.25	0.2 / 0.02	0.07
3/4	2	18	3.0 / 0.3	3.0 / 0.3	0.25 / 0.025	0.08
1	2	17	3.0 / 0.3	3.0 / 0.3	0.25 / 0.025	0.08
1-1/2	3	14	3.0 / 0.3	3.0 / 0.3	0.25 / 0.025	0.09
2	4	12.5	3.0 / 0.3	3.0 / 0.3	0.25 / 0.025	0.11

### 102-D7(HIGH SPEED) For Acetylene

PLATE THICKNESS (inches)	TIP SIZE	CUTTING SPEED (in/min)	OXYGEN PRESSURE (kg/c m <sup>2</sup> ) / (Mpa)		FUEL GAS PRESSURE (kg/c m <sup>2</sup> ) / (Mpa)	KERF WIDTH (inches)
			CUTTING	PREHEAT		
1/8	00	31.5	7.0 / 0.7	1.5 / 0.15	0.2 / 0.02	0.03
1/4	0	29	7.0 / 0.7	2.0 / 0.2	0.2 / 0.02	0.04
3/8	0	27	7.0 / 0.7	2.0 / 0.2	0.2 / 0.02	0.05
1/2	1	25	7.0 / 0.7	2.5 / 0.25	0.2 / 0.02	0.05
3/4	2	22	7.0 / 0.7	3.0 / 0.3	0.25 / 0.025	0.06
1	2	20	7.0 / 0.7	3.0 / 0.3	0.25 / 0.025	0.07
1-1/2	3	18	7.0 / 0.7	3.0 / 0.3	0.25 / 0.025	0.08
2	4	16	7.0 / 0.7	3.0 / 0.3	0.25 / 0.025	0.10

#### NOTE

- 1) All pressures are torch inlet pressures.
- 2) Oxygen purity is minimum of 99.7%.
- 3) Depending on the surface condition of the steel plate (scale, paint) either increase the fuel gas pressure or decrease the cutting speed. Also, when precision cutting is required, adjust all data.

**106(STANDARD SPEED) For Propane**

PLATE THICKNESS (inches)	TIP SIZE	CUTTING SPEED (in/min)	OXYGEN PRESSURE (kg/c m <sup>2</sup> ) / (Mpa)		FUEL GAS PRESSURE (kg/c m <sup>2</sup> ) / (Mpa)	KERF WIDTH (inches)
			CUTTING	PREHEAT		
1/8	00		1.5 / 0.15	1.5 / 0.15	0.2 / 0.02	0.04
1/4	0		2.0 / 0.2	2.0 / 0.2	0.2 / 0.02	0.05
3/8	0		2.0 / 0.2	2.0 / 0.2	0.2 / 0.02	0.06
1/2	1		2.5 / 0.25	2.5 / 0.25	0.2 / 0.02	0.07
3/4	2		3.0 / 0.3	3.0 / 0.3	0.2 / 0.02	0.08
1	2		3.0 / 0.3	3.0 / 0.3	0.2 / 0.02	0.08
1-1/2	3		3.0 / 0.3	3.0 / 0.3	0.2 / 0.02	0.09
2	4		3.0 / 0.3	3.0 / 0.3	0.25 / 0.025	0.11

**106-D7(HIGH SPEED) For Propane**

PLATE THICKNESS (inches)	TIP SIZE	CUTTING SPEED (in/min)	OXYGEN PRESSURE (kg/c m <sup>2</sup> ) / (Mpa)		FUEL GAS PRESSURE (kg/c m <sup>2</sup> ) / (Mpa)	KERF WIDTH (inches)
			CUTTING	PREHEAT		
1/8	00		7.0 / 0.7	1.5 / 0.15	0.2 / 0.02	0.03
1/4	0		7.0 / 0.7	2.0 / 0.2	0.2 / 0.02	0.04
3/8	0		7.0 / 0.7	2.0 / 0.2	0.2 / 0.02	0.05
1/2	1		7.0 / 0.7	2.5 / 0.25	0.2 / 0.02	0.05
3/4	2		7.0 / 0.7	3.0 / 0.3	0.2 / 0.02	0.06
1	2		7.0 / 0.7	3.0 / 0.3	0.2 / 0.02	0.07
1-1/2	3		7.0 / 0.7	3.0 / 0.3	0.2 / 0.02	0.08
2	4		7.0 / 0.7	3.0 / 0.3	0.2 / 0.02	0.10

## NOTE

- 1) All pressures are torch inlet pressures.
- 2) Oxygen purity is minimum of 99.7%, propane is minimum of JIS Grade 3.
- 3) Depending on the surface condition of the steel plate (scale, paint) either increase the fuel gas pressure or decrease the cutting speed. Also, when precision cutting is required, adjust all data.

---

<MEMO>

## **Handy Auto PLUS**

### **OPERATION MANUAL**

---

## **KOIKE SANZO KOGYO CO., LTD.**

Date of issue : May.2002

Printed in Japan

Second Sep.2002

Third Nov.2003

Fourth Sep.2008

Fifth Jan.2009

Sixth Jul.2009

Seventh Sep.2010

Eighth Jul.2011

Ninth Mar.2023

Tenth Jan.2024

Eleventh May.2024